



**Rectangular
Bucket 2LT**
Bucket technical
characteristics

Dimensions

D1XD2: 189.6 X 144.6 mm

D3XD4: 167.1 X 122.1 mm

H: 109.1 mm *without the lid*

Deviation ±1mm

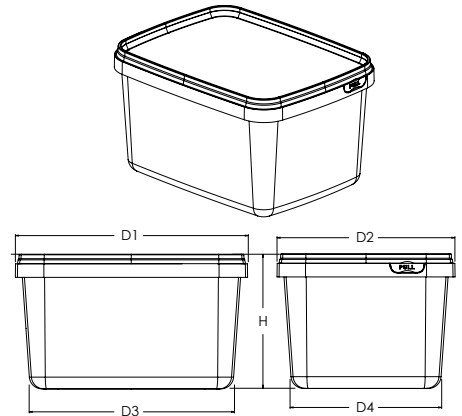

**Other
elements**

Capacity (LT)

Volume to rim
2080cc

Brim full volume
2265cc

Net weight / Deviation (±2.5%)

59gr

Buckets packaging

Carton 220 pcs

Decoration

IML Label



**Lid technical
characteristics**
**Rectangular
Lid 2LT**

Dimensions

D1: 186 mm

D2: 141.6 mm

H: 8,5 mm

Deviation ±1mm

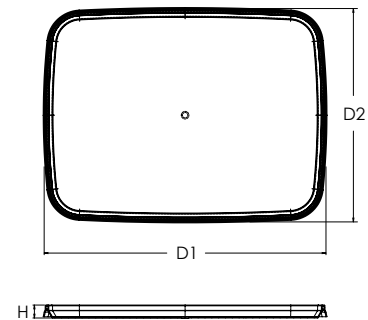

**Other
elements**

Lid weight (gr)
Deviation (±2.5%)

19 gr

Lid packaging

880 pcs/carton box

USEFUL STORAGE INFORMATION: To preserve the quality of this product, it is recommended that it be stored in its original packaging, away from any source of local heat and moisture, away from direct sunlight (below 30°C) and dry conditions. It is recommended that the product be allowed to reach operating temperature 24 hours before use.

RAW MATERIAL: Polypropylene (PP)



ISO 22000/ISO 9001/FSSC 22000

